



TECHNICAL DATA SHEET

Note: For safe, efficient blasting, read and follow the owner's manual and seek training for everyone who will use this equipment.

Purpose

The BNP gun directs a high-speed mixture of air and abrasive to quickly remove corrosion, mill scale, coatings, heat treatment residue, carbon buildup, tool marks, and burrs. The blast stream from a BNP gun can produce a uniform texture or create an etched finish to increase bonding strength for coatings.

High-performance blast gun provides comfortable grip for operator, and allows precise control of blast pattern. The BNP gun keeps the air jet and blast nozzle precisely aligned to maximize blast efficiency and minimize gun-body wear.

A knurled nut at gun outlet allows operator to change nozzles without tools. Gun accepts a variety of nozzles and extensions, so operator can select the best nozzle size and nozzle composition for the application.

Works with most recyclable blast media – glass bead, ceramics, aluminum oxide, and some sizes of steel grit and shot. Select appropriate blast media for your application.

Requirements for Operation

These items are required but not included with the BNP gun

- Suction blast nozzle – select from table on back
- Clean, dry compressed air of sufficient volume to maintain pressure at the blast nozzle. Volume required will depend on air jet selected (See table on back)
- Blast media – abrasive, stripping, or peening media suitable for the application

Description

High-production, hand-held blast cleaning gun for use in any suction blast cabinet. May be mounted in fixed position. Made from cast/machined aluminum. Gun assembly includes gun body, orifice with locknut, O-ring and nozzle holding nut. Order nozzle separately.



Fits the hand easily

BNP Suction Blast Guns



Cutaway shown

The BNP Gun; solid and easy to maintain

Description of Operation

The air jet at the back of the nozzle directs a high-speed stream of compressed air through the mixing chamber and out the nozzle. The rapid passage of this air generates negative pressure, causing blast media to flow into the mixing chamber and out the nozzle. This technology is widely known as venturi or suction blasting.

The operator holds the BNP gun at a predetermined distance and angle, relative to the surface being blasted. The BNP gun can clean, finish, orpeen the part being blasted. By moving the gun and the part, the operator quickly covers as much of the surface as needs blasting.

A cast-in hole at the top allows the operator to attach the BNP gun to a fixed bracket (not included). The part can then be moved under the nozzle for blasting, freeing the operator's hands to manipulate the part.

When the part is sufficiently processed, the operator releases the pedal to stop blasting.

Advantages

- Comfortable pistol-grip design reduces operator fatigue and increases productivity during prolonged blasting
- Precisely shaped mixing chamber eliminates slugging and uneven media flow common to inexpensive guns
- Standard ceramic nozzle works with most blast media. Optional tungsten carbide nozzles last longer than ceramic nozzles in most applications
- Optional boron carbide nozzles easily handle aggressive abrasives
- BNP gun accepts assorted air jet and nozzle sizes to take advantage of the available air supply
- BNP gun accepts extension nozzles and angled tip nozzles for special applications

Related Clemco Literature

Description	Stock No.
Pulsar III & VI brochure	20159
Abrasive Blasting Safety Practices	22090
Blast Off 2	09294
Pulsar IX brochure	23351

Item	Description	Stock No.
1.	BNP Gun assemblies less nozzle and hose assemblies	
	No. 4 gun	12301
	No. 5 gun	12302
	No. 6 gun	12303
	No. 7 gun	12304
	No. 8 gun	12305
2.	Nut, nozzle holding	11914
3.	Nozzle, ceramic	
	No.5	11930
	No.6	11931
	No.7	11932

Item	Description	Stock No.
	Nozzle, boron carbide	
	No.5	11935
	No.6	11936
	No.7	11937
	No.8	12894
	Nozzle, tungsten carbide	
	No.5	13118
	No.7	12882
	No.8	11942
4.	O-ring.....	08975
5.	Gun body	11802
6.	Lock nut, air jet	11913
7.	Rubber sleeve	12097
8.	Air jet assembly w/item 7	
	No.4	12342
	No.5	12343
	No.6	12344
	No.7	12345
	No.8	12346
9.	Hose end, 1/2" barb x 1/2" female swivel	15002
10.	Fitting, hose, 3/8" npt x 1/2" barb.....	06369
11.	Hose, air, specify feet required	12472
12.	Hose, media, clear urethane, specify length	12476

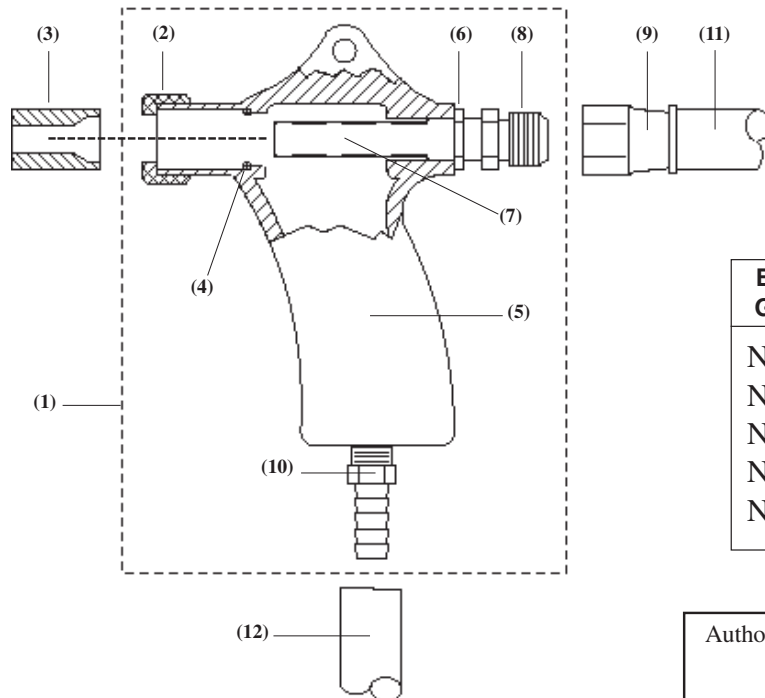

AIR CONSUMPTION

BNP GUN	NOZZLE ORIFICE	AIR JET	CFM at 80 PSI	M ³ /Min at 5,5 BAR
No. 4	5/16"	1/8"	21	0,60
No. 5	5/16"	5/32"	32	0,90
No. 6	3/8"	3/16"	48	1,35
No. 7	7/16"	7/32"	62	1,76
No. 8	1/2"	1/4"	85	2,41

Authorized Distributor:

Clemco is committed to continuous product improvement. Specifications are subject to change without notice.
Clemco Industries is an ISO 9001 certified company.